

# Chimney Hoods | DX ISLA Glass

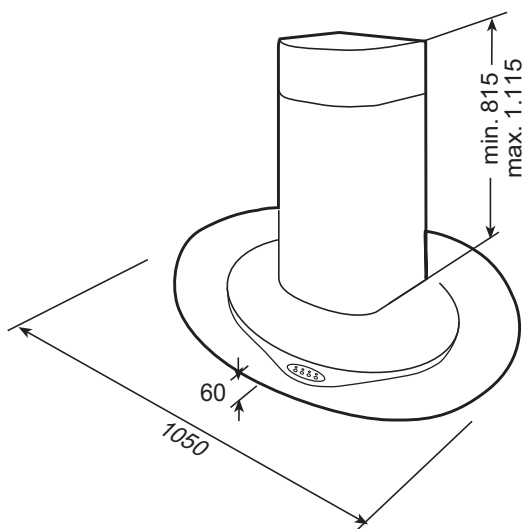

## TECHNICAL DRAWING



## CHARACTERISTICS

- Chimney hood
- Island concept
- Touch control panel
- Glass wind
- Double turbine motor
- Exhaust capacity: 800 m<sup>3</sup>/h
- 3 speeds + 1 intensive
- Integrated halogen lamps
- Stop delay timer
- Metal filters
- Stainless steel body
- Telescopic ducting tube
- Optional: Recirculation kit with charcoal filters

## Electrical connection

Maximum nominal power W	290
Motor power W.	250
Light power W.	40
Power rate V.	220/240
Frequency Hz.	50

## Features

Operating pilot	*
Nr. of motor	1DT
Armoured motor	-
Max. exhaust power m <sup>3</sup> /h	800
Noise level (dB.)	60
Air outlet (∅ mm.)	120/150
Metal filter	*
Optional recirculation kit	*
Nr. of power levels	3+1
Delay timer	*